

## INSTALLATION INSTRUCTIONS

DESCRIPTION: Side Case Kit, BLACK AND SILVER  
 PART NUMBER: BW3-F84B8-T0 / BW3-F84B8-V0 / 2BS-F84B8-T0 / 2BS-F84B8-V0  
 MODEL: '21+ Ténéré 700 Side Case and '12+ Super Ténéré



### **⚠ WARNING**

Improper loading can adversely affect handling.

- Do not exceed maximum load limit:  
 Super Ténéré 1200: 10 kg (22 lbs.) each saddlebag  
 Ténéré 700: 5 kg (11 lbs.) each saddlebag
- Distribute weight evenly from side to side.
- Read the Owner's Manual for important loading and tire pressure information.
- Total weight of rider, passenger, accessories, and cargo must not exceed the motorcycle load capacity shown in the Owner's Manual.
- Never ride with saddlebags above maximum speed shown because handling could be affected.  
 Super Ténéré 1200: 120 km/h (74 mph).  
 Ténéré 700: 130 km/h (80 mph).  
 This maximum speed may be reduced by such factors as improper loading, poor tire or overall motorcycle conditions, poor road surfaces, or adverse weather conditions.

### WARRANTY INFORMATION:

In the United States, see your Yamaha dealer for a copy of the Yamaha Genuine Parts and Accessories Limited Warranty.

### DEALER OR INSTALLER:

These instructions contain important information for future reference and *must* be given to the customer.

### NOTICE:

Installation of this kit requires a torque wrench and should be performed by an authorized Yamaha dealer or a qualified mechanic.

### PARTS LIST:

No.	Part Number	Description	Qty
--	<b>BW3-F84B8-T0 / 2BS-F84B8-T0</b>	Side Case Kit RIGHT	--
--	<b>BW3-F84B8-V0 / 2BS-F84B8-V0</b>	Side Case Kit LEFT	--
①	-	Compression Spring	2
②	-	Ball Bearing	2
③	-	Slide Cam Left	1
④	-	Slide Cam Right	1
⑤	-	Cap Head Bolt	4
⑥	-	Cam Latch Left	1
⑦	-	Cam Latch Right	1
⑧	-	Dust Cover	2
⑨	2PP-F81C0-V0	Cylinder Lock set- not included in this kit	-

\* Part supplied with kit only and not available separately.

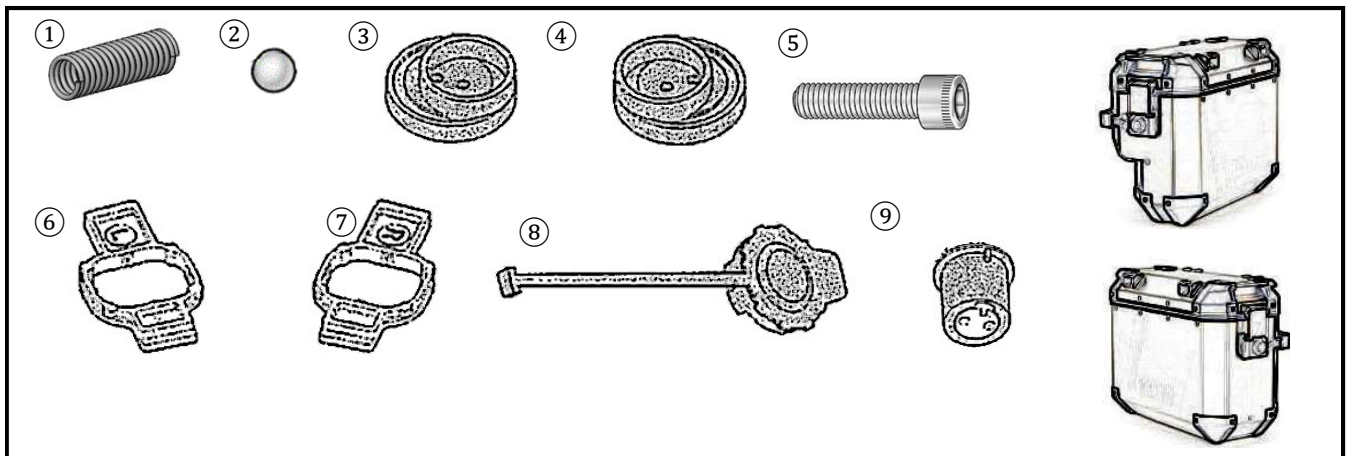

Fig. 1

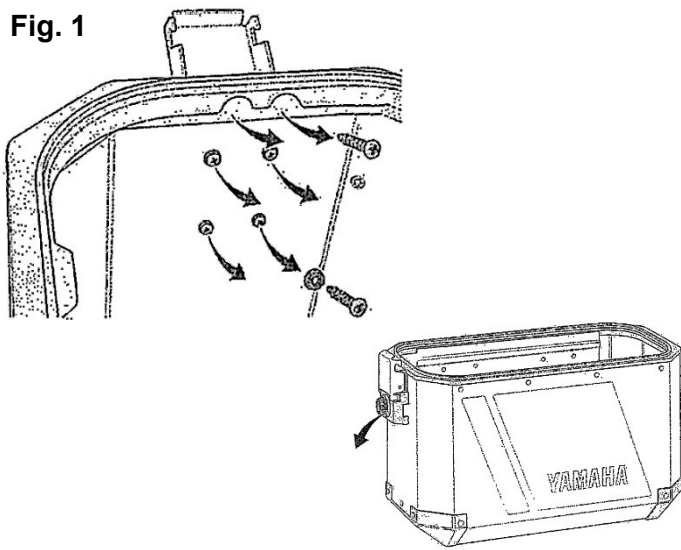

Fig. 2

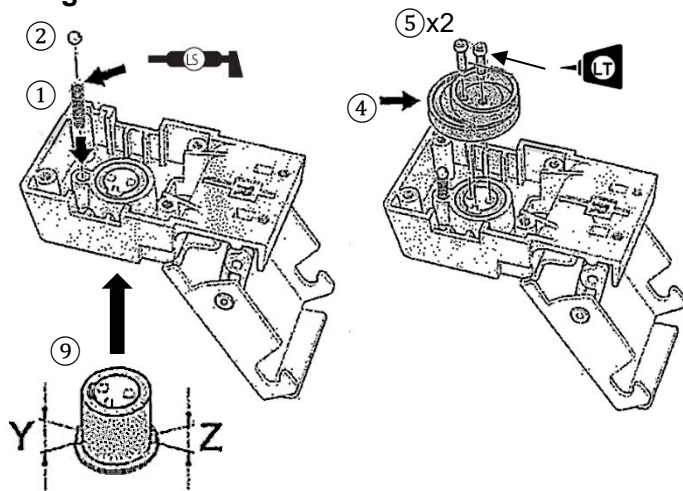
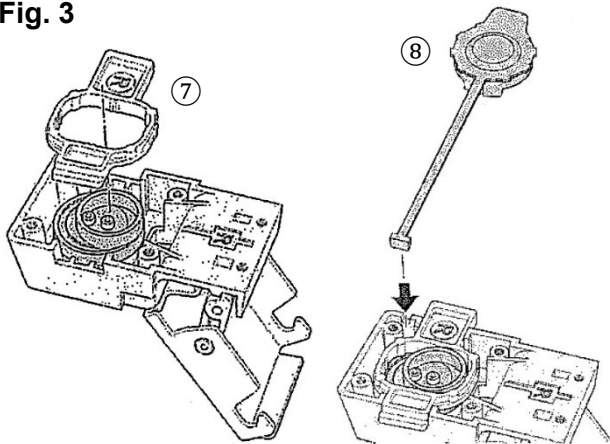

Fig. 3



### PREPARATION:

- Place the vehicle on a secure and level surface.
- Clean the mount surfaces before beginning installation.
- The **Cylinder Lock Set kit 2PP-F81C0-V0** is required for the side cases to be locked.
- The **2BS-F84G0-V0 Side Case Mount** kit is required for the Super Ténéré.
- The **BW3-F84G0-V0 Side Case Mount** kit is required for the Ténéré 700.

### INSTALLATION:

1. Remove the latch assembly from the inside the Right-side case. Retain the hardware because it will be reused. (Fig. 1)
2. Align and notch the ⑨ Cylinder Lock Set into the latch assembly. (Fig. 2)
3. Insert the ① Compression Spring into the indicated location in the latch assembly. (Fig. 2)
4. Lubricate the ① Compression Spring with Yamaha lithium soap based grease. Place the ② Ball Bearing on top of the ① Compression Spring. Tip: The grease helps hold the bearing in place. (Fig.2)
5. Place thread locker on two of the ⑤ Cap Head Bolts. Place the ④ Slide Cam Right on top of the ② Ball Bearing and ① Compression Spring and press the ④ Slide Cam Right down until it touches the back of the ⑨ Cylinder Lock Set. Hold it in place and thread in the ⑤ Cap Head Bolts. Torque to 0.7 Nm (0.07 kg-m or 0.5 lb-ft) (Fig. 2)
6. Place the ⑦ Right Cam Latch over the ④ Slide Cam Right with the smooth side facing the ④ Slide Cam Right. Insert the ⑧ Dust Cover into the notch on the latch assembly. (Fig. 3)
7. Install the latch assembly back in place on the side case using the stock hardware. (Fig. 4)
8. Repeat the process for the other case using the Left side parts from the kit.

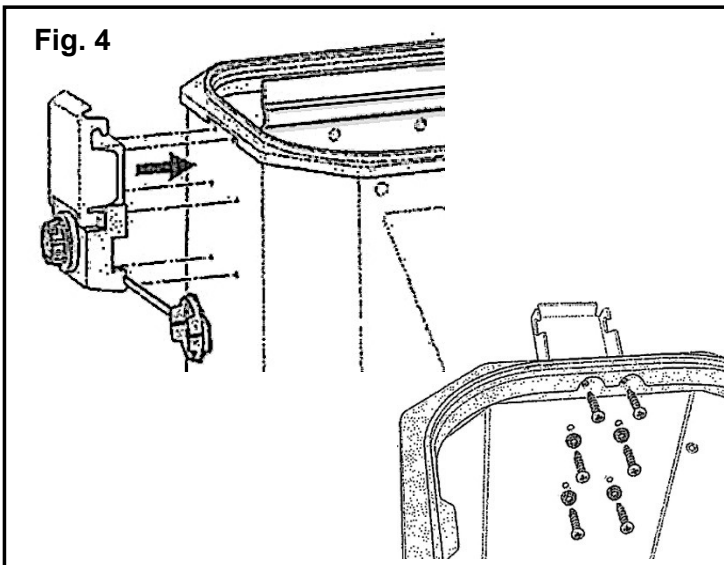

**MAINTENANCE:**

Periodically, check torque on all hardware. If loose hardware is found, re-torque to specification.

**CARE AND CLEANING:**

Clean painted metal parts with a clean soft cloth and mild soap and water solution. Rinse and dry.

**CUSTOMER SERVICE:**

For further information see your Yamaha dealer.

**ESTIMATED TIME TO INSTALL: 0.5 HRS.**

